

| Part Number |
|-------------|
| 30545 |

Allen Field Company, Inc.

256A Orinoco Drive
 Brightwaters NY 11718
 (800) 535-0810
 www.allenfield.com

Product Image



Related Item

30544



| Product Description | |
|-----------------------|--------------------------|
| Item Name | 545 Swivel Hanger Tab HD |
| Size | 2.50"(W) x 1.22"(H) |
| Material | Polyethylene |
| Ordering Information | |
| 305451035 | White |
| 305458035 | Black |
| Packaging Information | |
| Carton Pack/MOQ | 5000 pcs/ctn. |
| Carton Weight | 35.2 lbs. |

Product Dimensions

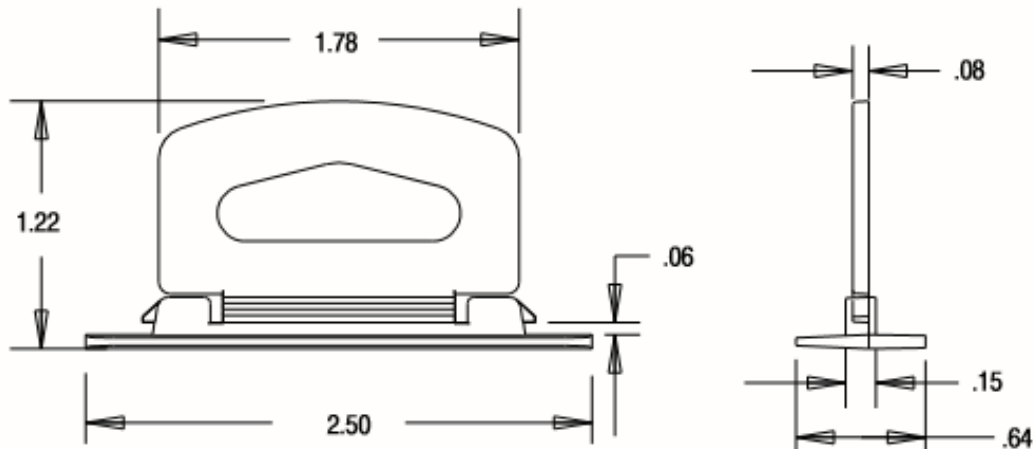

Die-Cut Dimensions

