

Part Number
BP626

Allen Field Company, Inc.

256A Orinoco Drive
 Brightwaters NY 11718
 (800) 535-0810
 www.allenfield.com

Product Images

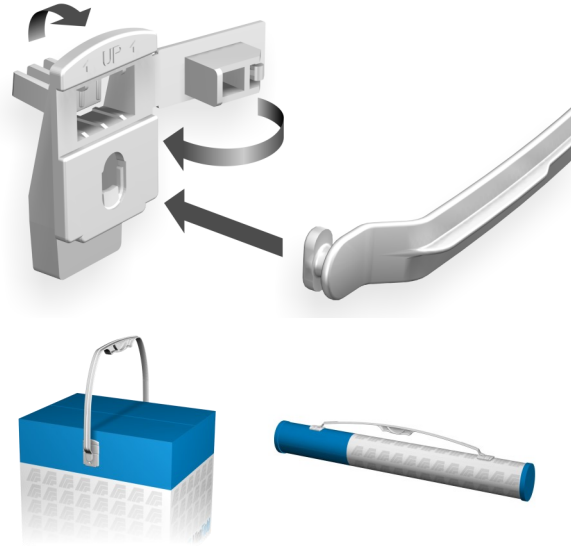

Product Description	
Item Name	Bucket Handle Adaptor
Size	1.97" (L) x 1.40"(W)
Max. Board Thickness	0.33"
Material	PP
Ordering Information	
BP626	Translucent
Packaging Information	
Carton Pack/MOQ	1500 pcs/ctn.
Carton Weight	34.5 lbs.

* Use in conjunction with Bucket Handle - P/N: 350026

Product Dimensions

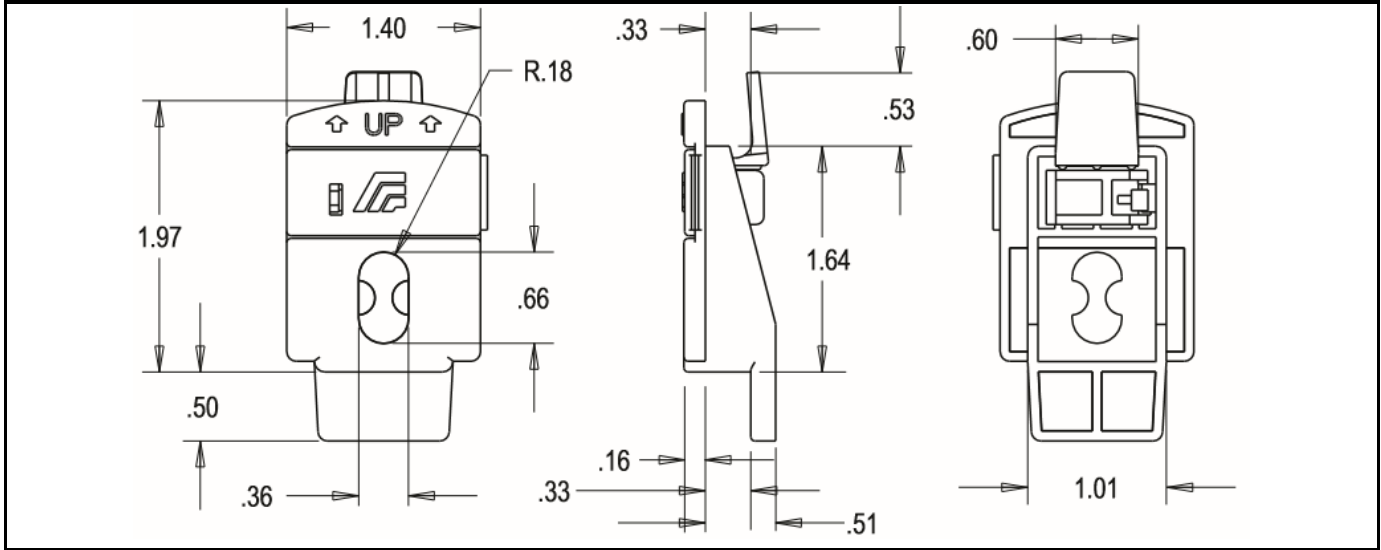

Di-cut Dimensions

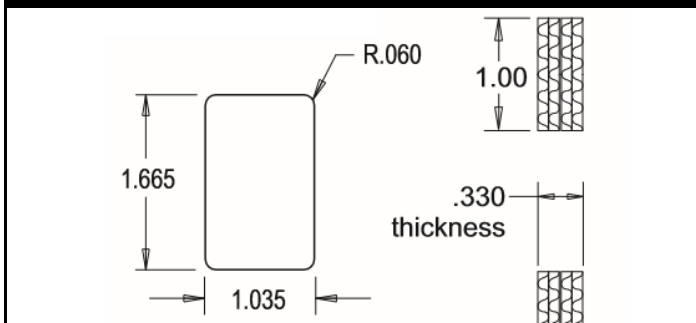

Box Dimensions

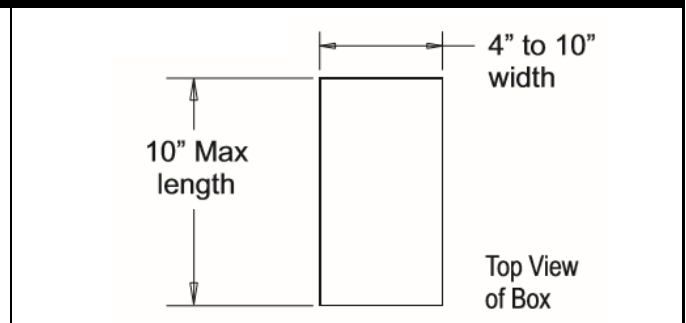

Part Tolerance — +/- .03 inches (.75mm)

Dimensions are in inches